

ISSUE	DATE	CHANGES
1	10-03-17	FIRST ISSUE
2	16-03-17	GENERAL UPDATE
3	17-03-17	TANK TROUGH DETAILS CHANGED

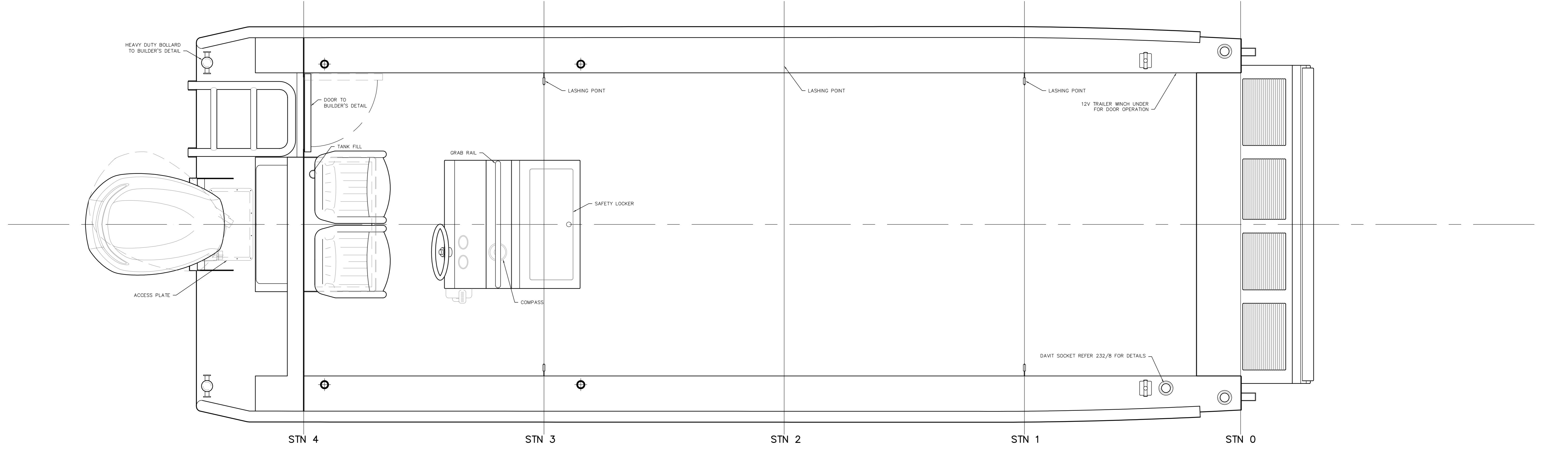
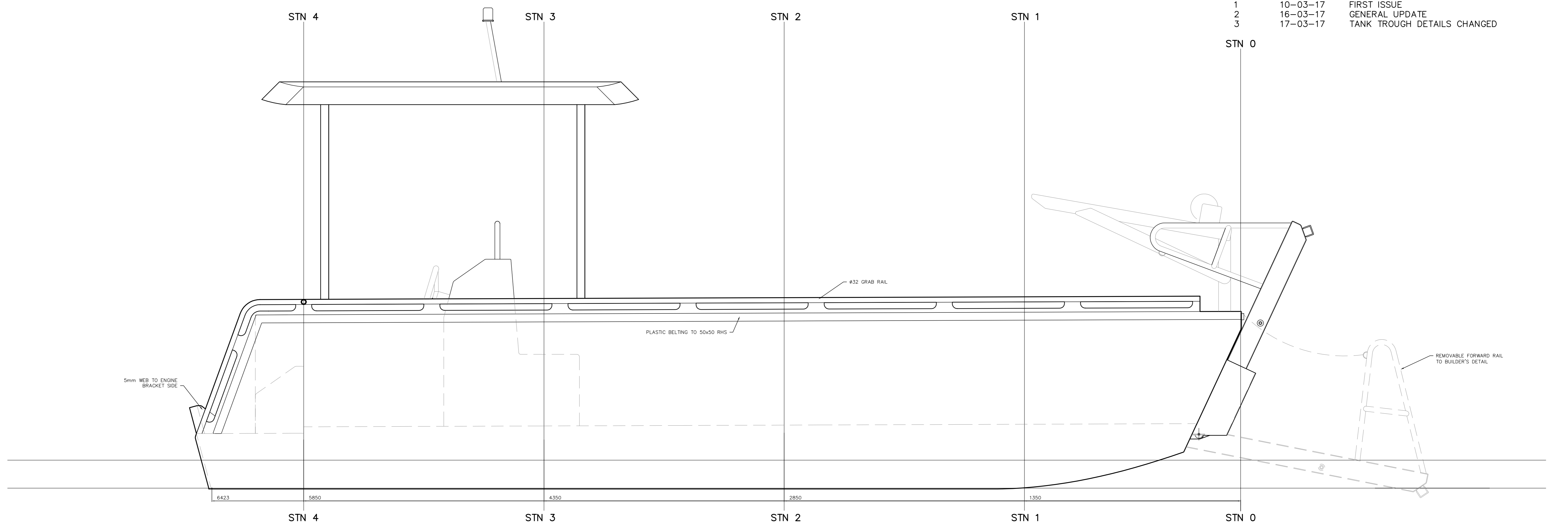

PRINCIPAL PARTICULARS

LOA:	6.5m	DEPTH:	0.35m	SURVEY:	2E (4)
MEASURED LENGTH:	6.25m	DISPL:	1700kg	TANKAGE:	80 L
BEAM:	2.5m (WITH BELTINGS)	SERVICE SPEED:	30 KNOTS	FLOTATION:	LEVEL
DRAFT:	0.16m (LIGHTSHIP)	ENGINE:	130 HP	RAMP RATING:	1 TONNE (END ON SHORE)

CHRIS TUCKER MARINE DESIGN PTY LTD.
 PO BOX 194, OLINDA, VICTORIA, 3788, AUSTRALIA
 PHONE +61 (0)3 9728 1754, INFO@CTMD.COM.AU

**6.5m LANDING BARGE
 FOR ALUMARINE
 GENERAL ARRANGEMENT**

BY DATE SCALE DRWG
 CT MAR '17 1:12 @ A1 232/1
 ISSUE 3

THIS DRAWING MAY NOT BE COPIED, COMMUNICATED TO ANY PERSON OR USED FOR MANUFACTURE WITHOUT THE EXPRESS WRITTEN CONSENT OF THE DESIGNER.